



## High Output Compression Driver

The P Audio BM-D750 is a state of the art high output compression driver. Advanced engineering and manufacturing methods have produced an extremely reliable and wide bandwidth device that also features very high fidelity.

The BM-D750 is a large format titanium based diaphragm assembly mated to a close spaced circumferential phase plug geometry. The voice coil is a rectangular geometry high temperature aluminum to insure extended high frequency response.

The large 2 inch (51mm) throat exit makes the 750 an excellent choice for high sound pressure level performance. This large throat insures low distortion and high intelligibility, particularly thru the critical upper vocal range. High fidelity thru the upper vocal range translates to increased intelligibility and clarity in this critical upper vocal range. This throat diameter is an industry standard for high output vocal range compression drivers and will mate to a variety of P Audio 2 inch throat horns as well as many commercially available high frequency horns.

The Ferrite based permanent magnetic system produces a very high efficiency to weight and size ratio. This makes the BM-D750 ideal for high level professional touring applications as well as high level fixed installation systems.

### Specifications

Throat Diameter	2.0 inch (50mm)
Diaphragm Diameter	3.0 inch (76mm)
Nominal Impedance	8 Ohm
Voice Coil DC Resistance	6.2 Ohm
Power Handling	100 Watt
Sound Pressure Level (1W@1M) (Loaded with 90x40 Horn)	112 dB
Mounting Type	Bolt On
Magnet	Ferrite
Diaphragm Material	Titanium
Recommended Crossover	1kHz or higher (12dB/Oct slope)
Net Weight	4.9kg (10.8lbs) 1pc
Gross Weight	5.1kg (11.2lbs) 1pc
Packing Dimension HxWxD(cm)	18.7 x 18.7 x 11.7 (0.15 Cu.Ft.)

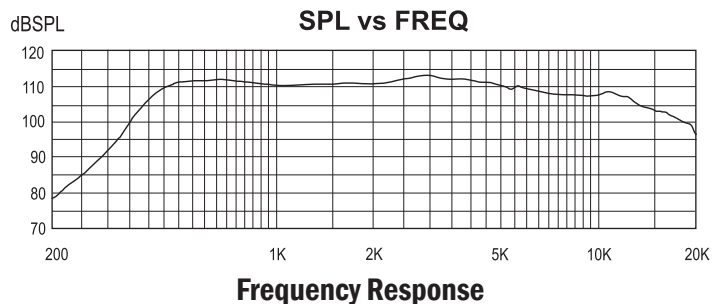
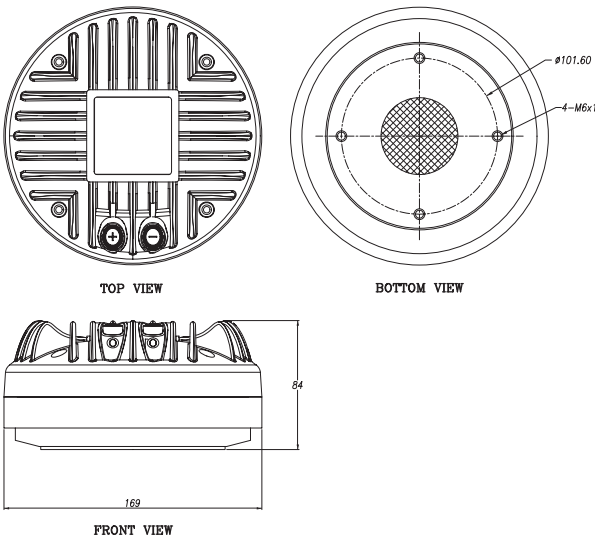

19/4 Moo 2 T.Bangkratuk A. Samparn Nakornpathom 73210 Thailand  
 Tel: +66-2-441 6600 Auto 30 Lines  
 e-mail: info@paudiothailand.com  
 Web site: www.paudiothailand.com  
 All rights reserved by P.Audio System Co., Ltd. 2007

